

Two side fully coated multilayer SBS board

Ensocoat 2S is a luxurious, coated SBS (solid bleached sulphate) board with a three-layer fibre construction. It is double-pigment-coated on the top side and on the reverse side.

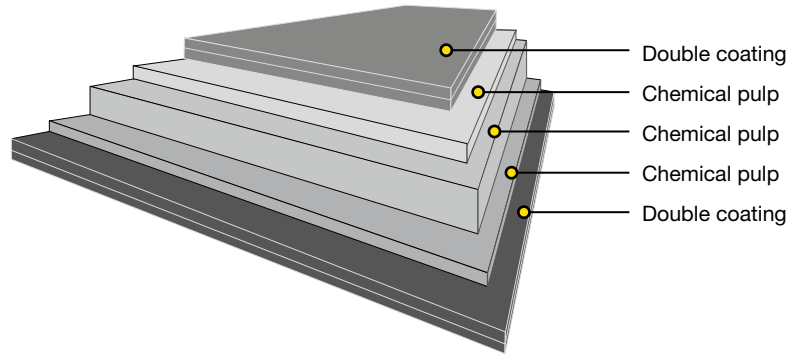

Issued: 12.2022
Cancels: 09.2021

Technical specification

Typical properties, US	Tolerance								Method
	9.1	10.1	11.5	13.0	14.2	15.8	17.8		
Caliper, pts									
Nominal basis weight, lbs/1000 sq.Ft.	45.1	49.2	55.3	61.5	67.6	71.7	81.9		
Bending moment Taber MD, gcm	42	64	94	128	169	217	320		
Bending moment Taber CD, gcm	23	30	44	64	82	106	153		
Scott Bond, Lbfft/1000 in ²	105	105	105	105	105	105	105		
Typical properties, Metric									
Thickness, µm	±4%	230	255	290	330	360	400	450	ISO 534
Grammage, g/m ²	±4%	220	240	270	300	330	350	400	ISO 536
Bending resistance L&W 15° MD, mN	-15%	85	130	190	260	350	440	650	ISO 2493-1
Bending resistance L&W 15° CD, mN	-15%	47	60	90	130	170	215	310	
Bending moment Taber 15° MD, mNm	-15%	4.1	6.3	9.2	12.6	16.9	21.3	31.4	
Bending moment Taber 15° CD, mNm	-15%	2.3	2.9	4.3	6.3	8.2	10.4	15.0	
Bending stiffness DIN 5° MD, mNm	-15%	7.2	11.1	16.2	22.1	29.8	37.4	55.3	
Bending stiffness DIN 5° CD, mNm	-15%	4.0	5.1	7.7	11.1	14.5	18.3	26.4	
Moisture, %	±1, ±1.5 *	6.5	6.5	6.5	6.5	6.5	6.5	6.5	ISO 287
ISO Brightness C/2°, %	min. 92	95	95	95	95	95	95	95	ISO 2470-1
Brightness D65/10°, %		103	103	103	103	103	103	103	ISO 2470-2
CIE Whiteness D65/10°		135	135	135	135	135	135	135	ISO 11475
L* D65/10°		96.5	96.5	96.5	96.5	96.5	96.5	96.5	ISO 5631-2
a* D65/10°		2.5	2.5	2.5	2.5	2.5	2.5	2.5	
b* D65/10°		-10.5	-10.5	-10.5	-10.5	-10.5	-10.5	-10.5	
Surface Smoothness PPS 10, µm	max. 1.4	0.9	0.9	0.9	0.9	0.9	0.9	0.9	ISO 8791-4
Surface Smoothness Bendtsen, ml/min		20	20	20	20	20	20	20	ISO 8791-2
Gloss 75°, %		48	48	48	48	48	48	48	ISO 8254-1
Scott Bond, J/m ²	min. 140	220	220	220	220	220	220	220	TAPPI 569

Optical and surface properties valid for both sides.

*) For 350 – 400 g/m²

All properties according to Imatra Mill measurements from board machine production.
Laboratory test climate 23°C/50% RH (According to ISO 187).
Tolerances based upon 95% confidence limits, apply to delivered reel/pallet average.
Bending moment Taber 15° and Bending resistance L&W 15° are binding, Bending stiffness DIN 5° are indicative.
Bending moment Taber 15° calculated from Bending resistance L&W 15°.

Two side fully coated multilayer SBS board

Certificates

Quality management ISO 9001
 Environmental management ISO 14001
 Product safety FSSC 22000
 Occupational health and safety ISO 45001
 Energy management ISO 50001



FSC and PEFC certified board available upon request.

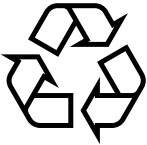

Paperboard is recyclable

Key characteristics and main enduses

Ensocoat is Stora Enso's flagship brand, crafted to meet the demands of the graphical industry and luxury packaging. Ensocoat 2S is a two-side-coated option, for a symmetrical appearance on both sides of the board. Its surface smoothness, printing performance, brightness, whiteness, UV-light resistance and reverse-side print result have been optimized to impress even in the most demanding applications. Produced from responsibly sourced, certified raw materials, it serves as the industry standard for high performance and sustainability. Ensocoat 2S is used for book covers, tickets & tags, greeting cards, brochures, folders and calendars and in cosmetics and perfume packaging. Thanks to the three-layer fibre construction, Ensocoat 2S has outstanding strength, folding, embossing and converting properties.

Printing and finishing techniques

The product can be used with different printing techniques such as offset, flexo and digital printing. In digital printing, the product is suitable for several different sheet- or web-fed presses. Dry or liquid toner technology can be used, although in some cases, pretreatment of the substrate might be required. The latest certification status can be verified on the press manufacturer's website or with local Stora Enso representatives. It is important to check the limitations of the equipment, particularly because of the exceptional difference in the thickness and stiffness of board compared with paper in the same grammages. When running thicker substrates, the press manufacturer's recommendations should be referred to for optimal grain direction. Essentially all of the same finishing processes apply to both digitally printed and offset printed work. Since a wide variety of digital printing equipment is available in the market, it is important that a new commercial print job is always preceded by a trial run, including all required printing and converting process phases.

The product works very well with different finishing techniques, such as embossing, hot foil stamping and others. It is suitable for laser coding. Certificates according to PTS-DF 105/2013 and PTS-DF 103/2011 are available upon request.

Storage recommendations

For optimal printing results, the moisture proof wrapping should not be removed until the board has reached the temperature of the press room.

Pallet/Reel Weight (kg)	Difference in temperature between board and press room (press room temp. approx. 68°F)		
	50°F	68°F	86°F
881 lbs	2 days	2 days	3 days
1763 lbs	2 days	3 days	4 days
2645 lbs	2 days	4 days	5 days

The product properties, according to the specifications, are guaranteed for 12 months after the production date. In order to ensure product safety, the product must be well wrapped and stored indoors, sheltered from rain and snow. The recommended storage conditions are 50-55% relative humidity and 68-73.4°F.